

Items Supplied >

- 1 – FRONT MUFFLER BODY
- 1 – REAR MUFFLER BODY
- 2 – CLAMP, COBRA T-BOLT 268-65
- 3 – BOLT, HEX FLANGED M8 X 16 mm

Application(s) >

KAWASAKI VN1700 CLASSIC / LT 09-13

Instruction Manual >

4225

Page 1 of 2

PRIOR TO INSTALLATION, MAKE SURE YOUR STOCK HEADPIPE TO MUFFLER GASKETS ARE IN GOOD SHAPE. IF YOU HAVE ANY DOUBTS AS TO THEIR CONDITION, REPLACE THEM.

Read all instructions carefully and completely before installing your new exhaust system

1. Loosen the rear headpipe heatshield and front headpipe mid heatshield by loosening the M6 bolts securing clamps at the front and rear of shields, (Note rear has an 8 mm head and the front has a 10 mm head.) Do not remove the heatshields entirely, only loosen to allow them to rotate to access muffler clamps, see Figure 1 for clarification of stock heatshield clamp.
2. Loosen the stock muffler clamps for both front and rear mufflers by gaining access from under respective heatshields, the clamps have a 12 mm bolt head.
3. Remove the lower (front cylinder) muffler first by removing two M8 bolts securing muffler to lower bracket and one M8 bolt connecting lower muffler to upper muffler. These 3 bolts will not be reused. Remove muffler by pulling towards rear of motorcycle, be careful not to damage graphite gasket, as it must be removed from stock muffler and reused in Cobra® Mufflers, unless 2 new gaskets have been purchased direct from Kawasaki, Original Part Number: 11061-0240
4. To remove upper muffler loosen M10 Nut and Bolt on upper bracket. Be sure to hold muffler securely – then remove M10 nut and bolt from mounting bracket. Retain this bolt and nut for use later. Remove upper muffler by pulling rearward. Remove graphite gaskets as performed on front muffler.
5. Remove new Cobra slip on mufflers from box. Install graphite gaskets until fully seated in slip collars. Install the muffler T-bolt clamps onto each muffler as shown in Figure 1. Clamp tightening nuts must be oriented as shown facing outward on the bottom to allow access to tighten from under heatshields.
6. Slide upper muffler onto rear cylinder headpipe. Be sure stock headpipe heatshield is still in place as well as muffler clamp. Slide muffler forward until muffler slip is fully engaged and upper mounting bracket aligns with upper frame bracket. Insert stock M10 bolt through muffler bracket, stock washer / rubber grommet mount assembly and install stock nut on backside. **DO NOT TIGHTEN!**
8. Slide lower muffler onto front cylinder headpipe. Be sure stock headpipe heatshield is still in place as well as muffler clamp in proper orientation. Slide muffler forward until muffler slip is fully engaged and lower muffler bracket holes align with stock lower angle bracket holes. Insert two supplied M8 x 16 mm flange bolts through lower muffler bracket and into angle bracket. **DO NOT TIGHTEN!**
9. Install supplied M8 x 16 mm flange bolt through upper muffler rear bracket and lower muffler upper bracket, **DO NOT TIGHTEN!**

** Cobra® recommends you always wear a helmet while riding. Please never operate your motorcycle while under the influence of alcohol and/or drugs. Enjoy the new look of your motorcycle and please ride safely.*

10. Position each heatshield rear clamp over the front of each muffler. Align each heatshield between muffler and headpipe. Be sure heatshield front clamps does not fall off heatshield mounting lip.
11. Align muffler to be parallel with each other and tighten the upper muffler mounting bolt and nut (M10) to frame. Next tighten the M8 flange bolt joining the upper and lower mufflers together. Tighten the M8 lower muffler mounting flange bolts to the stock angle bracket. Tighten all bolts to factory specifications.
12. Now be sure the Cobra T-bolt clamps at the front of each muffler are in the proper position as in figure 1. Tighten securely. NOTE: (If the muffler clamps are slid to far up the muffler or past the two slots, the clamps will not tighten properly possibly allowing the mufflers to leak.)
13. Position rear cylinder heatshield to be parallel with upper muffler and tighten front and rear clamps, 8 mm and 10 mm bolt heads.
14. Position front cylinder mid heatshield to be parallel with lower muffler. Tighten front and rear heatshield clamps securely, 8mm and 10 mm bolt heads.

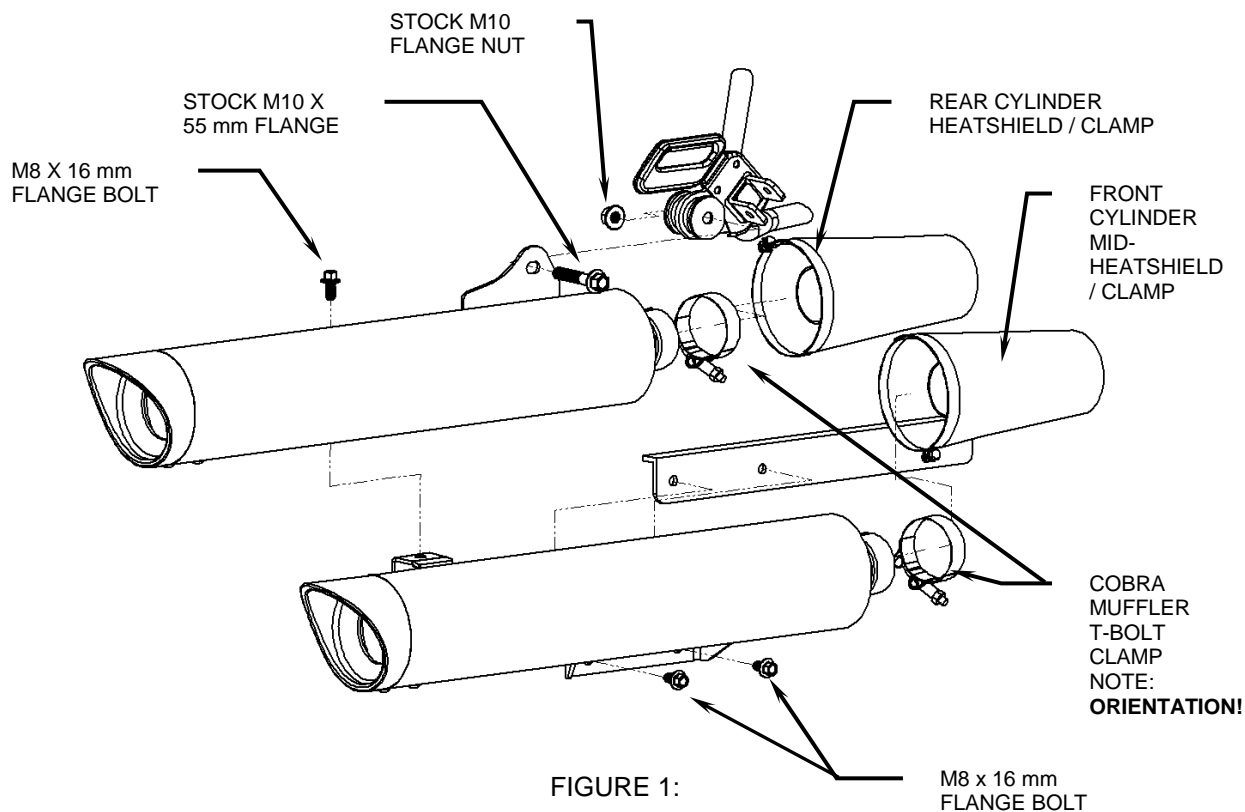

California does not allow the use of aftermarket exhaust systems that remove original equipment catalysts, (except for racing use only) unless the Air Resources Board has issued an Executive Order for that system.