

CHOKE KNOB INSTRUCTIONS



4668 Mission Blvd.
Montclair, CA 91763
909-613-0028
www.jokermachine.com
sales@jokermachine.com

CATALOG NO. 02-58, 02-59, & 950109

STOCK H/D CHOKE KNOB

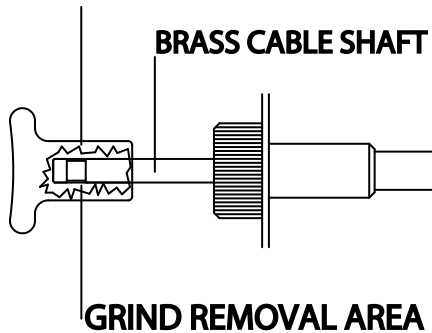

JOKER KNOB

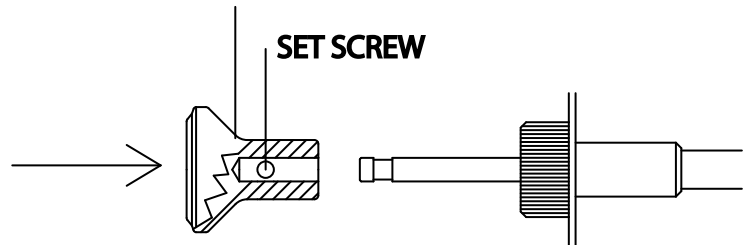

INSTALLATION

The stock choke knob is molded around a brass cable shaft and must be removed as follows below to avoid any un-due damage to the shaft/cable assembly.

Use of dremel tool (small grinder), is recommended for removing the plastic knob from the brass choke shaft.

Grind in the area shown very carefully paying close attention to the shaft area as not to grind into it.

The object here is to weaken the plastic enough to be able to grab onto the knob with pliers and twist sideways when you feel enough material has been removed.

Remove any plastic residue from the shaft (if any), and install the Joker Machine knob pushing it all the way onto the shaft until it bottoms out in the part.

Remove the set screw in the Joker knob and apply blue loctite. Re-install the screw.

Align the engraving as to see it in a level position and tighten the set screw onto the shaft.